

IT Tubo nero in speciale compound di PVC-P antiestrazione, con rinforzo tessile in fibra di poliestere e copertura in PVC-P. Superficie interna ed esterna completamente lisce, buona resistenza ad agenti atmosferici, sostanze chimiche, ozono e oli minerali. Molto flessibile, leggero e maneggevole.

• Trasporto di carburanti (benzina), lubrificanti, oli minerali.

EN Black hose made of special antimigration PVC-P compound, reinforced with polyester yarn and PVC-P cover. Completely smooth inside and outside, good resistance to weathering, chemicals, ozone and mineral oils. Very flexible, light and easy to handle.

• Transport of fuels (petrol), lubricants, mineral oils.



ARIANNA TA FUEL

COD. AT11 · Ø mm 5-10



Tubo in PVC-P antiestrazione
antimigration PVC-P hose

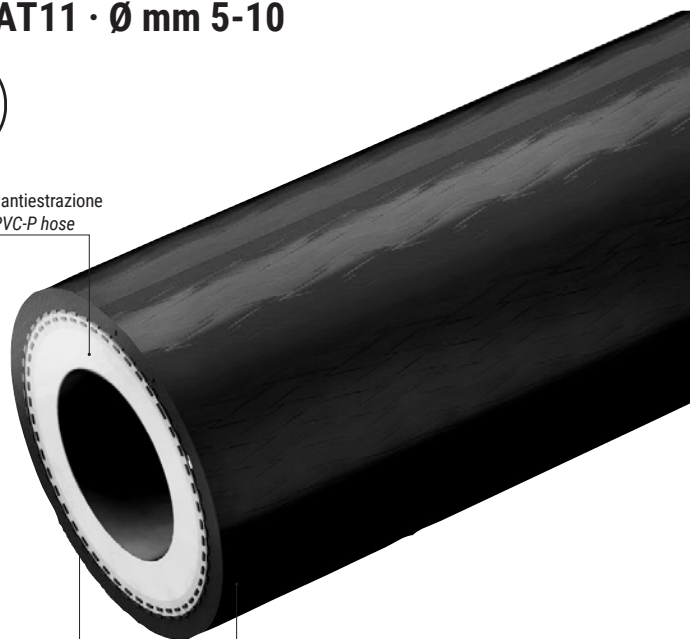

Copertura in PVC-P
PVC-P cover

Rinforzo tessile in fibra di poliestere
Polyester yarn reinforcement

ARTICOLI DELLA STESSA SERIE · ITEMS IN THE SAME SERIES



ARIANNA TA

SCHEMA TECNICA · TECHNICAL DATA

ARIANNA TA FUEL	Ø int.	Ø est./ out	Peso Weight	P.E. W.P.	P.S. B.P.	R. curvatura Bending r.	Lg. Rotolo Coil lgth.	Volume	Disponibilità Availability
CODICE/CODE	mm	mm	g/m	bar	bar	mm	m	m ³	
AT110050010000*	5	10	80	29	87	30	100	0,020	su richiesta/on request*
AT110060011000*	6	11	95	21	63	30	100	0,023	su richiesta/on request*
AT110080013000*	8	13	115	23	69	40	100	0,028	su richiesta/on request*
AT110100016000*	10	16	170	25	75	50	100	0,041	su richiesta/on request*

* Diametri su richiesta per quantitativi minimi (MOQ), salvo disponibilità a magazzino · * Diameters available on request for minimum order quantities (MOQ), unless in stock

I dati tecnici riportati sono stati misurati a 23°C e al 50% di umidità
The technical data here reported have been measured at 23°C with 50% humidity